

SAFETY AND OPERATIONS MANUAL

EVO TRACKED MACHINES



**Protech Machinery Ltd
WOOLRIDGE FARM
HARTPURY
GLOUCESTERSHIRE
GL19 3BG**



EC DECLARATION OF CONFORMITY
Conforming to EEC Directive 98/37/EC

We Protech Machinery Ltd

Of Woolridge Farm,
Gloucester Road,
Hartpury,
Gloucestershire.
GL19 3BG

Hereby declare that the product: **POSTDRIVER**
Product Code **EVO**
Serial Number series

Manufactured by the above Company complies with the required provisions of the Directive 98/37/EC

To effect the correct application of the safety requirements stated in the EEC Directives, the following standards and/or technical specification have been used:

BS EN ISO 12100 : 2010 Safety of Machinery - General principles for Design; Risk assessment & risk reduction

BS EN 953 : 1997 + A1 : 2009 Safety of Machinery - Guards: General requirements for the design & construction of fixed & moveable guards.

BS EN 349 : 1993 + A1 : 2008 Safety of Machinery - Minimum gaps to avoid crushing of parts of the human body.

BS EN 13857 : 2019 Safety of Machinery – Safety distances to prevent hazard zones being reached by upper & lower limbs.

BS EN 4413 : 2010 Hydraulic fluid power - General rules & safety requirements for systems & their components

BS 5401: 1990 Guide to information content and presentation of operator's manuals provided for tractors and machinery for agriculture and forestry.

Signed

On behalf of Protech Machinery

Date...Friday, 30 April 2021



LIST OF CONTENTS

LIST OF CONTENTS.....	3
INTRODUCTION.....	4
PRODUCT SPECIFICATION.....	5
DIMENSIONS - TRANSPORT.....	7
PARTS REFERENCE.....	9
SAFETY STATEMENT.....	11
INTERPRETATION AND UNDERSTANDING THIS MANUAL.....	12
SAFETY INFORMATION.....	13
PERSONAL PROTECTIVE EQUIPMENT.....	16
EMERGENCY STOPS / SAFETY DEVICES.....	17
HAZARDS AND SAFE USE OF THE MACHINE AND EQUIPMENT.....	18
MACHINE OPERATION.....	19
MACHINE SAFETY DECALS.....	20
CONTROL FUNCTIONS OF THE POST DRIVER.....	21
SLEW ARM	21
TELESCOPIC ARM	22
REAR LEG	22
MAST FORWARD TILT	23
MAST SIDE-TILT	24
DRIVER WEIGHT CONTROL	25
TRACK EXTENSION	25
TELEMAST CONTROL	26
ROCK SPIKE CONTROL	27
AUGER DRIVE	28
AUTO-LEVEL	30
Auto-level setup.....	31
REMOTE CONTROL	32
WELDER	34
INITIAL CHECKS BEFORE OPERATION.....	35
OPERATING THE DRIVE MOTORS AND MOVING THE MACHINE.....	36
USING THE POST DRIVING EQUIPMENT.....	37
ELECTRICAL FUNCTIONS.....	38
Switches and Controls	38
Junction box	39
Circuit Diagrams	40
Engine diagram	41
Engine control box	42
MAINTENANCE.....	43
TRACK TENSION	44
RECOMMENDED LUBRICANTS	Error! Bookmark not defined.
ENGINE SERVICING	45
TROUBLE SHOOTING.....	46
CHECKLIST.....	47



INTRODUCTION

IMPORTANT NOTICE

This manual must be read and fully understood before operating this machine. Whenever any doubt exists please contact Protech Machinery for assistance. If the machine is resold the Manual must be transmitted to the new owner.

Dear customer,

Thank you for purchasing a Protech EVO Post Driver. Protech machinery Ltd has produced this User Guide to assist and help you get the most from your post driver.

This manual is line with the relevant Health and Safety regulations to assist you with operating this machine without harm to yourself.

You should be aware that any person operating this machine with your permission must be given adequate guidance and information to allow him or her to use the machine safely.

Whereas every effort has been made to ensure the Post Driver conforms to Protech policy of quality, the machine cannot be expected to withstand abuse caused by misuse and negligence by the operator.



PRODUCT SPECIFICATION

Each machine will have a degree of customization. Final definition on each sales order.

EVO COMPACT Standard configuration

- ✓ 1.52mtr wide track base
- ✓ 320mm wide tracks
- ✓ Extending track 500mm
- ✓ 26hp Yanmar engine
- ✓ Single speed tracking
- ✓ Electric park brake
- ✓ 250kg hammer
- ✓ 2 way mast tilt
- ✓ 120 degree slew
- ✓ Hydraulic mast leg
- ✓ Telescopic mast (3.5mtr post clearance)
- ✓ Centre post carrying frame
- ✓ Front post carrying frame
- ✓ Operator stand
- ✓ Wire unroller with hinge down spindle
- ✓ Hydraulic rock spike with 75mm diameter spike

EVO1S Standard configuration

- ✓ 1.6mtr wide track base
- ✓ 400 mm wide tracks
- ✓ Extending Track 500mm
- ✓ 48hp engine
- ✓ 2 speed tracking
- ✓ Electric park brake
- ✓ 300kg hammer
- ✓ 2 way mast tilt
- ✓ 120 or 60 degree slew
- ✓ Hydraulic Mast leg
- ✓ Telescopic mast (3.5mtr post clearance)
- ✓ Large Post Carrying Frame
- ✓ Front post carrying frame
- ✓ Operator Stand
- ✓ Wire unroller with hinge down spindle
- ✓ Hydraulic rock spike with 75mm diameter spike

EVO 2S Standard configuration

- ✓ 400kg hammer (1100lb)
- ✓ 400mm wide tracks
- ✓ 2.1 metres width chassis
- ✓ Yanmar 67 HP engine Stage 5 compliant
- ✓ 180 degree slew arm
- ✓ Poclain transmission
- ✓ LED working lights
- ✓ servo oil tracking control
- ✓ 2 speed tracking
- ✓ 800mm (31.5") telescopic slew arm
- ✓ 4 way mast tilt
- ✓ Hydraulic mast stabilising leg
- ✓ Hydraulic Front Blade
- ✓ Centre post carrying frame
- ✓ Hydraulic front post frame 800mm (31.5") extension
- ✓ Auger drive hydraulic system
- ✓ 3" / 75 mm diametre rock spike and hydraulic extractor
- ✓ 1000mm (39.5") telescopic mast extension (can drive 12ft posts)
- ✓ park brake
- ✓ emergency stop
- ✓ all controls at rear of machine
- ✓ rear drawbar
- ✓ rear foot stand



GROUND PRESSURE

EVO COMPACT weight: 2,500 kg
320mm Track surface : 9,400 cm², Ground pressure : 0.27 Kg / cm² or 3.8 PSI

EVO 1 weight : 2,950 kg
380mm Track surface : 12000 cm², Ground pressure : 0.25 Kg / cm² or 3.5 PSI
320mm Track surface : 10112 cm², Ground pressure : 0.29 Kg / cm² or 4 PSI

EVO 2 weight : 4,500 kg
380mm Track surface : 12000 cm², Ground pressure : 0.37 Kg/cm² or 5.3 PSI
450mm Track surface : 13,500 cm² Ground pressure : 0.33 Kg/cm² or 4.7 PSI

NOISE LEVEL

The data below is depending on the usage conditions, atmospheric situation and shall not be taken as contractual figures but give a fair view of the noise levels encountered when working on the machine. The base data comes from YANMAR.

The displayed noise curves below are intended to represent the “continuous noise level” of the machine at work, and do not include the instantaneous element of weight drop on the fencing posts. The noise generated by the post-driving activity is obviously depending on the nature of posts (wood type, metal type), size of post, and soil type (clay, rock, earth). Also, the frequency of “noise spikes” generated by the post-driver is very intermittent, it is therefore not represented below.

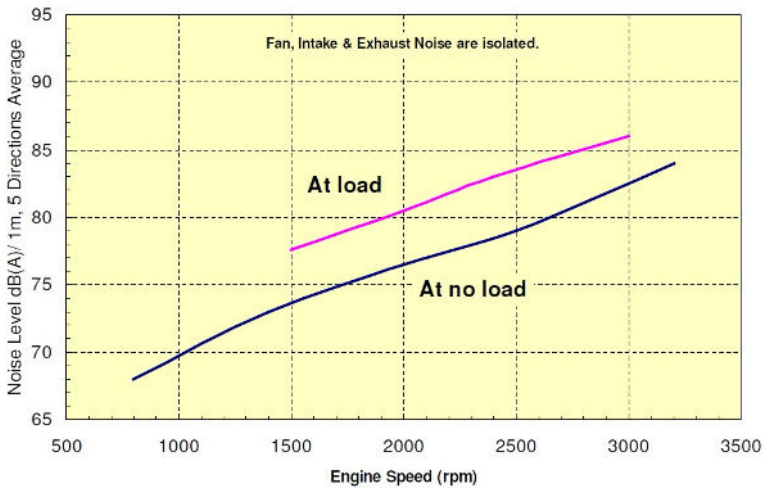

EVO COMPACT – 3TNV76

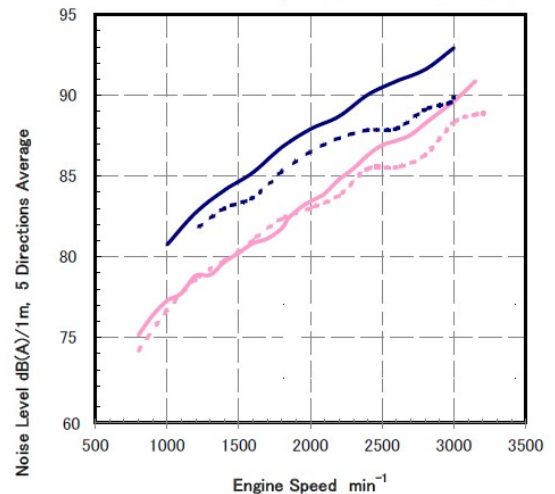

EVO 1 & 2 – 4TNV88 YANMAR



DIMENSIONS - TRANSPORT

EVO1S is fitted with a mast rest bracket on which the mast should be laying when transporting the machine. A “stay bar” is also provided to protect the tilt cylinder. This can be set in position with 2 lynch pins. This is to avoid mast hydraulic cylinders to receive road vibrations and will extend life of cylinders.

Four lashing shackles are fitted on the track base, which gives safe attachment points when travelling the machine.

	EVO COMPACT	EVO1S
Machine overall max height	4.9 m	4.9 m
Overall Length (retracted front post tray)	3.25 m	3.7 m
Overall machine Width	2.1 m	2.2 m
Track base width (track to track)	1.54 m	1.6 m
Weight (excl. options to add below)	2500 kg	2940 kg
Auger + drills	110 kg	110 kg
Front blade	100 kg	100 kg
Elec winch	50 kg	50 kg
Hyd rock spike	30 kg	30 kg
Hyd post twister	30 kg	30 kg
Radio control	15 kg	15 kg
Auto-level	10 kg	10 kg

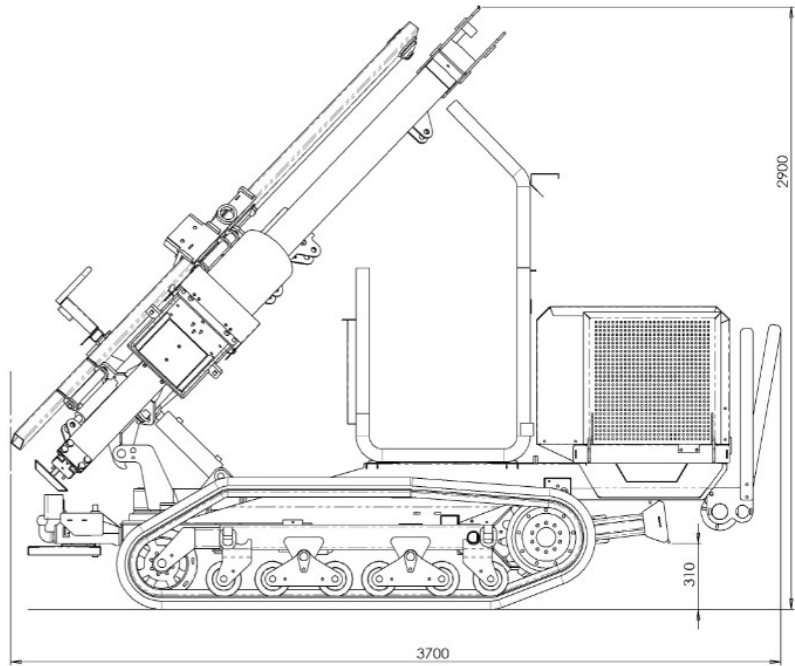
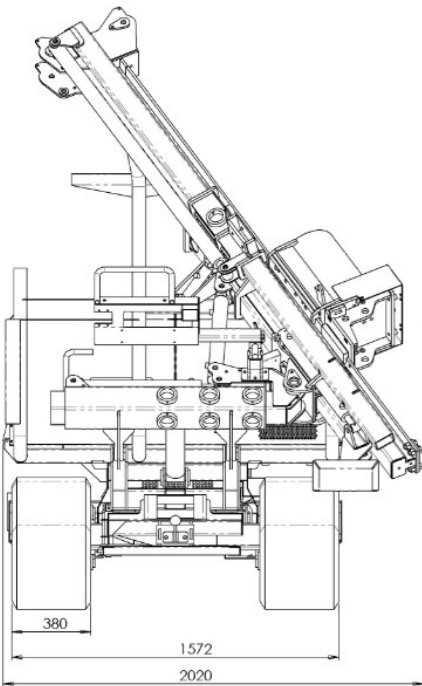
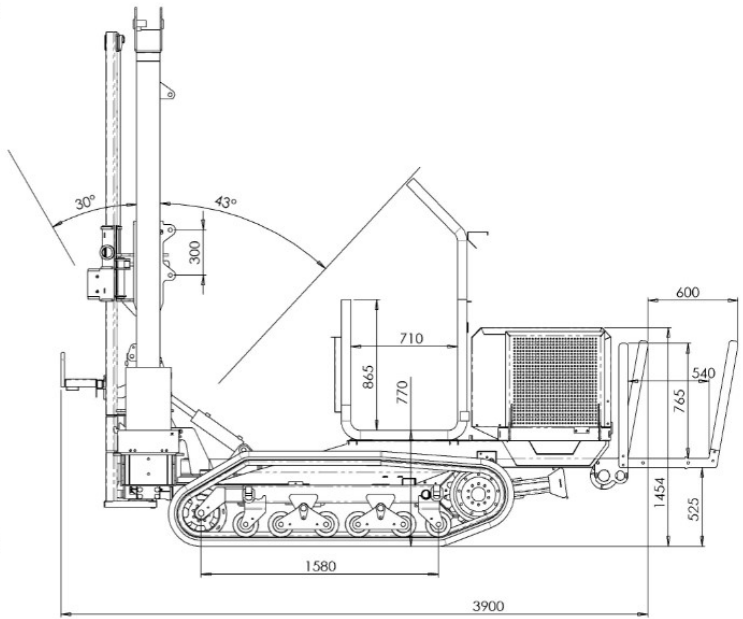
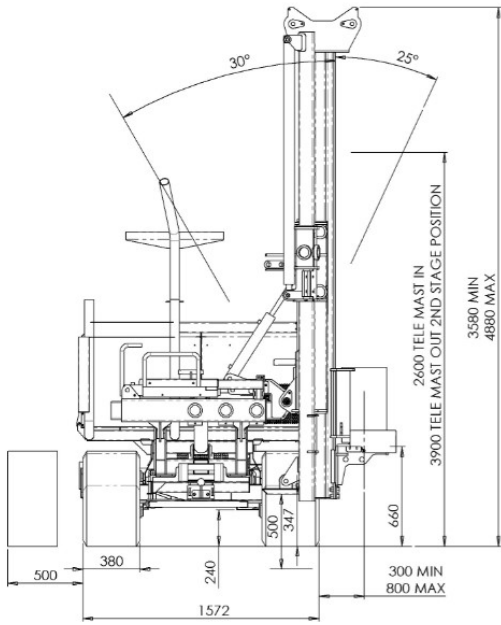

PARTS REFERENCE

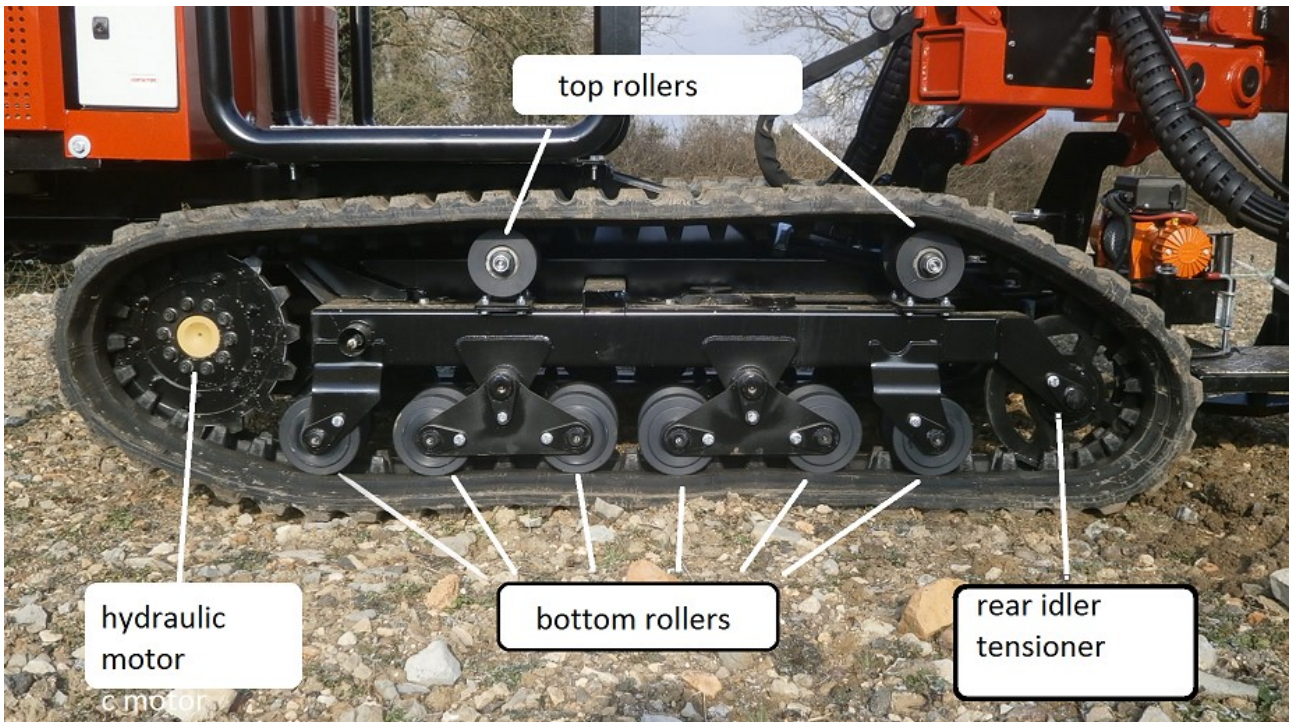
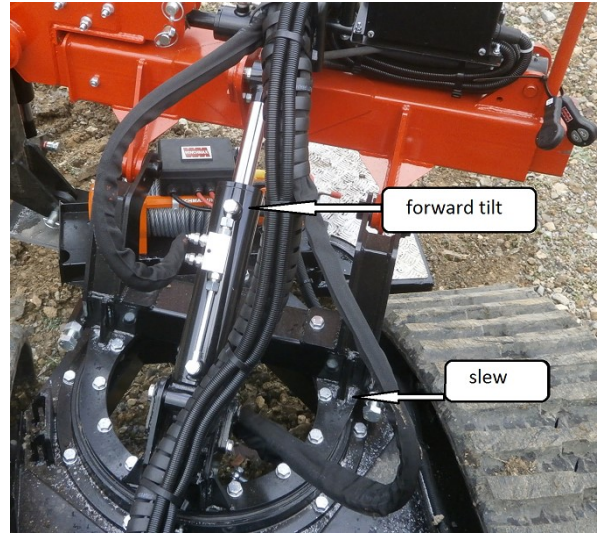
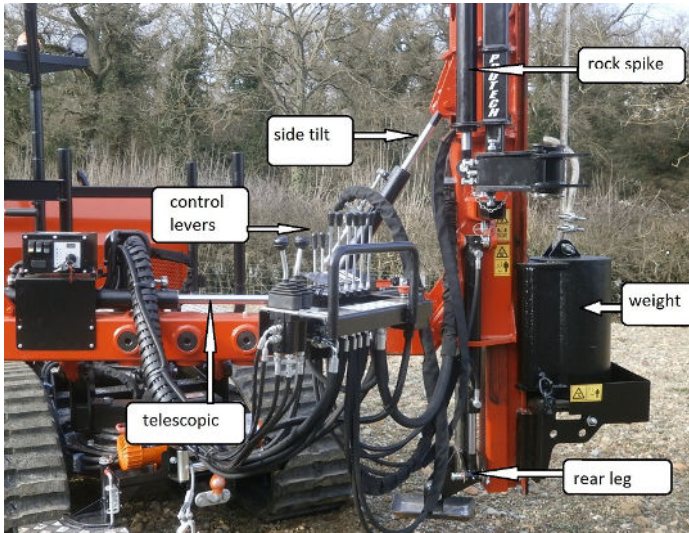

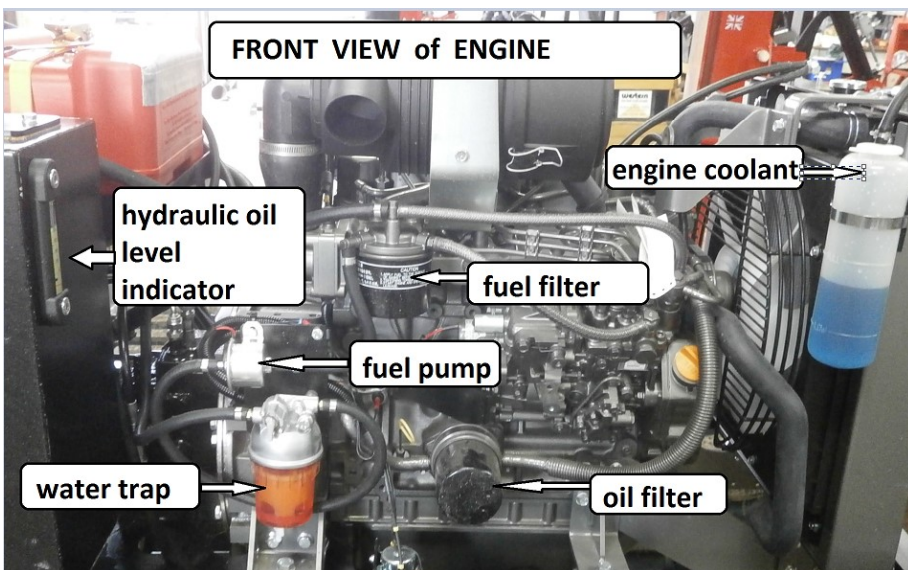
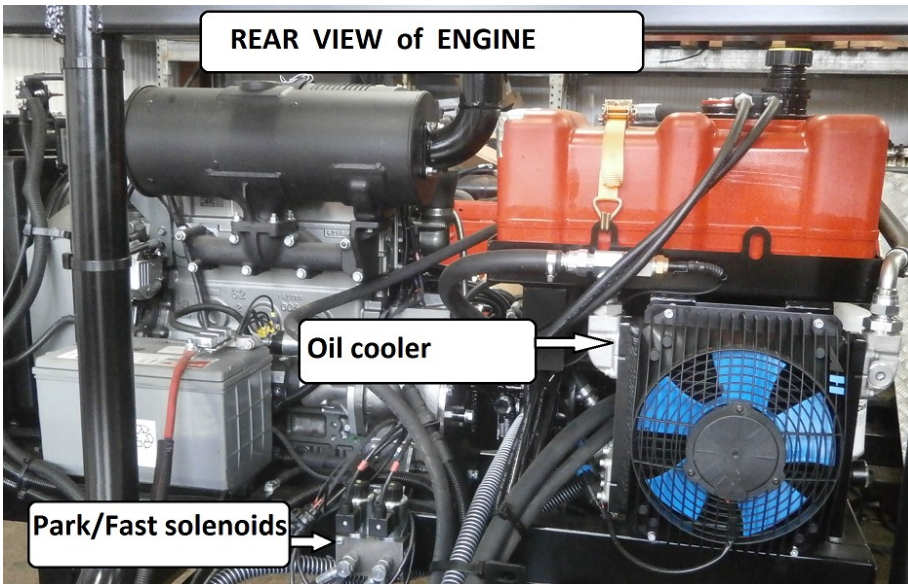
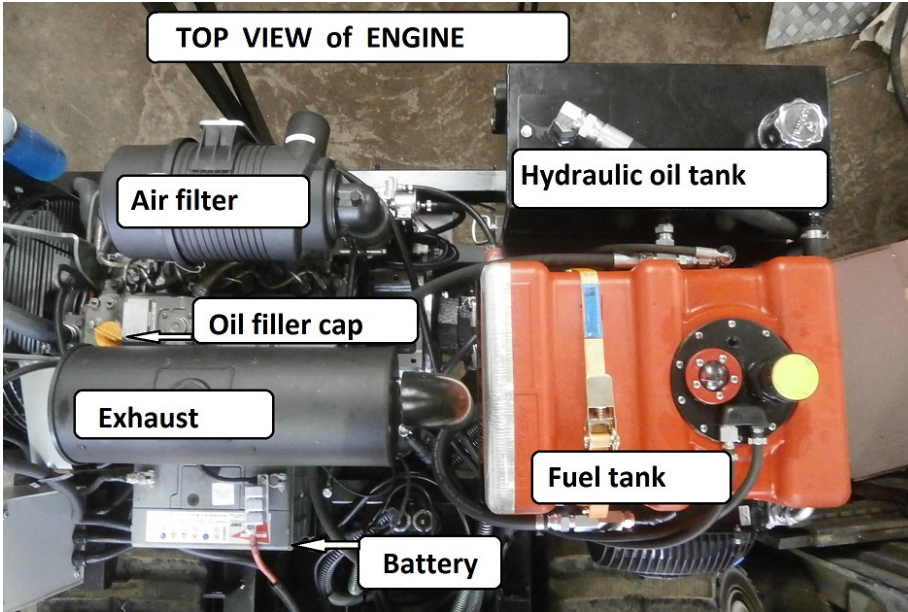



SAFETY STATEMENT

Protech Machinery Ltd are concerned for your safety and that of others around you when operating this machinery and its associated equipment. This safety statement is our primary way of notifying you and bringing to your attention the potential hazards associated with the EVO Series track machines and its equipment.

We advise that you follow the precautions listed throughout this manual before operation, during operation and during routine maintenance procedures for your safety and for the safety of others.

Protech Machinery Ltd advice that the minimum age for the safe operation of this machinery and equipment be at least 18 years of age.

Protech Machinery Ltd also advice that a form of basic training be carried out before operating the machinery and its equipment. This will be provided to the end user upon receipt of the machine and its equipment. A certificate of competence will be issued on completion of basic training.

For further training requirements please contact Protech Machinery Ltd. Please keep all warning labels and symbols from becoming dirty or defaced so others may be able to read and understand the hazards associated with this machine and its equipment. When replacing parts with a warning label or symbol attached to it, please ensure that the labels or symbols are also replaced.

Please keep this manual available at all times in the protective cover supplied with it to prevent defacement of this manual. If I doubt about operation of this machine please refer to this manual for guidance or contact Protech Machinery Ltd.

Failure to read and understand this manual before operation including misuse of this machinery and equipment could lead to injuries, severe injuries with life changing consequences or even **DEATH**.

Protech Machinery Ltd cannot be held liable for any injury or death caused by operator negligence, misuse of this machinery and equipment or general breach of the standard health and safety practices within the work place

INTERPRETATION AND UNDERSTANDING THIS MANUAL

Protech Machinery Ltd have produced this manual to ensure that you have a safe and full understanding of the EVO Track Machines and their equipment.

Throughout this manual you will find various warning symbols indicating a potential hazard associated with the machines and equipment.

Please read this manual carefully and understand the operation of the machinery and equipment before use.

Although every effort has been made to warn you of the dangers there is no substitute for good common sense and safe practices.

We at Protech Machinery Ltd want you to get the most from your machine in a safe and responsible manner at all times.



CAUTION

This yellow caution triangle is to indicate a potentially hazardous situation which, if not avoided, may result in minor or moderate injury



DANGER

This red danger triangle is to indicate a potentially hazardous situation, which if not avoided, could result in **DEATH** or **SERIOUS INJURY**



This machine has the potential to be extremely dangerous - in the wrong hands it can maim, cause serious injury or even kill. It is therefore imperative that both the owner and operator of the machine reads and understands the following section to ensure they are fully aware of the dangers that do, or may exist, and their responsibilities surrounding the use and operation of the machine.

The operator of this machine is responsible not only for their own safety but equally for the safety of others who may come into close proximity of the machine. When the machine is not in use it should be parked on a firm level site and the starting key removed.

In the event of any fault being detected with the machine operation it must be stopped immediately and not used again until the fault has been corrected by a qualified technician.

- Before starting the machine the operator must read and understand all aspects of use and maintenance of the machine as stated in this manual
- The machine must only be used by a responsible adult who is familiar with all aspects relating to safe operation
- The machine must not be operated by children or non-authorized persons
- Operators must know the meaning of all operation and safety decals on the machine
- Operators must know the procedure for switching the machine off normally and by using the Emergency Stop
- Do not attempt to use the machine if the Emergency Stop switch is damaged or malfunctioning.
- Never use the machine with safety removed or defective
- Operators should practice on flat open ground to familiarise themselves with driving and manoeuvring the machine before attempting to use it on sloping ground



- Never leave a running machine unattended. Always switch the engine off and remove the ignition key
- Always stop and switch off the machine if persons or animals enter the work area. Do not restart the machine until they are at a safe distance.
- Never use the machine to perform a task it was not designed for.
- Never allow persons to ride on the machine.
- It is the users responsibility to protect persons in or near the work zone
- When servicing or maintaining the machine no one should be allowed beneath it when it is raised unless it is securely supported on suitable ramps or stands.
- Never attempt to service or maintain the machine whilst it is running: always switch off the engine and remove the starting key
- Beware of stored energy in the hydraulic circuits when the machine is switched off.
- Always press the Emergency Stop switch before refuelling.
- Wherever possible refuel the machine before work when the engine is cold. If refuelling during work, switch the engine off and allow to cool before adding fuel.
- Test the Emergency Stop switch before each period of work to ensure it functions correctly.
- Never leave the ignition key in the machine control unit where it could be started and used by unauthorised persons.
- Never stand in front of the machine when it is being operated.
- Always wear PPE (personal protective equipment)



POTENTIAL SIGNIFICANT DANGERS ASSOCIATED WITH THE USE OF THIS MACHINE:

Injuring of feet. No person must be in this area when the Post Driver is raised or lowered by the tractor or near to the rear leg and foot plate when operating this control.

Crushing under the falling weight. No person must be near the post when the weight is falling. **Never put a hand on top of the post or rock spike under any circumstances.**

A trapping zone created by the movement of the tracks, moving forward in the area of the hydraulic blade (if available) and backwards in the area of the platform and the control panel.

A trapping zone from the forward and side tilting mast, no person must be in this area.

A trapping zone between the Slew arm and Main frame, no person must be in this area.

Electrocution from Overhead Power Lines (by contact with or flashover from).

Being hit by flying debris such as splinters from wooden posts.

Injection of high pressure oil from damaged couplings or hydraulic hoses.

Misuse of hydraulic accumulator, which is filled up with 350 bar nitrogen pressure

Beware of low bridges and other overhead obstructions, always measure and be aware of the maximum height when transporting the machine.



PERSONAL PROTECTIVE EQUIPMENT

It is advised that the following personal protective safety equipment be worn at all times when operating this machinery.

EC Personal Protective Equipment Directive (89/686/EEC).



- Eye wear to a minimum of high energy low impact protection.
- Face shield for high energy and high impact protection, (advised).
- Hearing protectors with active noise reduction.
- Safety boots.
- High visibility clothing.
- Hard wearing safety gloves.

EMERGENCY STOPS / SAFETY DEVICES

Each machine produced has an emergency stop buttons fitted to it.

The emergency stop when actuated will stop the engine immediately.

Caution must be taken as some hydraulic movement is still possible due to the effects of gravity and stored energy, machine mechanism weights and fluid return when control levers are moved.

To operate the emergency stop, strike the red button towards its base. The button will push down and lock into place and stop the engine.

To reset the button, pull the button away from its base and it will lock back into place.

To then start the engine, the ignition must be turned off and on again.

Regular operational checks of the emergency button should be performed.

Do not use the emergency stop button as the normal stopping method. Please use the ignition key as this will prevent premature wear or damage to the device.

Below is an image of the hydraulic control levers with the emergency stop button situated to the right hand side.



HAZARDS AND SAFE USE OF THE MACHINE AND EQUIPMENT



Failure to observe the following could result in *Serious Injury* or *Death*

There are many hazards posed when operating an EVO Track Machine or the equipment attached to it. When using the machine or equipment please be aware of the following:

- This machine was not designed for use on a public highways, schools, parks or any other place where the general public have access to it. If using the machine in these areas, a full and detailed risk assessment should be carried out and documented. Once completed, the area of interest or where the work will commence should be isolated from public access and deemed a dangerous area with clear warning signs and markings.
- A competent person should be with the machine at all times when the engine is running so that in the event of an emergency the engine can be stopped.
- Never leave the key in the ignition when unattended.
- Never leave the machine with the weight in the raised position
- When the machine is stationary, please apply the park brake to prevent self-tracking in the event of a control failure or accidental movements. These machines are designed for off road use in low grip conditions. They have the ability to drive over and crush people or animals with ease.
- Some EVO Track Machines have a very high tele masts option so extra caution should be taken when working near or under power lines. One other major factor to consider is lightning strikes when working out in the open in poor conditions.
- Take extra caution when working in a transverse position perpendicular to the slope of the hill. When moving around the machine in these conditions always, walk uphill and across the high side.
- Where possible, always use the post driving equipment on the high side to help balance the machine and prevent a roll over situation.
- If the machine has the extending track base option, always extend the tracks fully in these conditions giving a wider footprint.

These machines are heavy, some are almost 5 tons and can travel at 10 km/h with a high center of gravity. Please take extra care when using them. We at Protech Machinery want you to get the most out of your machine, but in a safe and responsible manner.



MACHINE OPERATION

BEFORE USING THIS MACHINE YOU MUST:

Ensure you read and fully understand all sections of the operator handbook,

Ensure the operator has been properly trained to use this machine.

Ensure the operator has been issued with, reads and fully understands the operator handbook.











The post cap plate must be used to hold posts at all times. Under no circumstances should the post be held manually while operating the Post Driver.

Only the operator must control the Post Driver, Spectators must be kept away from the machine at all times.

As part of the machine check-up, but not restricted to :

- Ensure that all safety guards are fitted and in good condition.
- Ensure that machine fittings and couplings are in good condition.
- Ensure that all warning labels are always visible and not damaged, defaced or missing
- Ensure the operator is protected from noise. Ear defenders should be worn.
- Ensure the operator is protected from flying debris. Safety glasses should be worn.
- Always check for worn hydraulic components.
- Always ensure the rope is not damaged. Replacements must be a certified Protech rope.
- When working on sloping ground, it is far safer to drive up and down rather than across the slope.

MACHINE SAFETY DECALS

	<p>Standard Triangle to indicate Alert/Warning</p>
	<p>Warning read Product Manual</p>
	<p>Warning danger area from tilting mast</p>
	<p>Warning danger of feet being crushed.</p>
 <p data-bbox="352 1155 533 1234">Eye protection must be worn</p>	<p>Warning eye protection must be worn</p>
 <p data-bbox="352 1245 533 1323">Ear protection must be worn</p>	<p>Warning ear protection must be worn</p>
	<p>Warning Danger of falling weight</p>
	<p>Warning Danger of overhead cables</p>
	<p>Lubrication Point</p>
	<p>Warning danger of fingers and hands being crushed</p>

CONTROL FUNCTIONS OF THE POST DRIVER

The photo below displays the layout of the control panel. Moving the control lever up or down operates the function in the direction displayed of the Post Driver.



SLEW ARM

Operating the slew control lever pivots the slew arm from parallel to the main frame through 120 degrees.



As the control is mounted to the slew arm, it will move with operation of the slew control. The operator must work in the control area of the post driver to avoid all trapping zones.



TRAPPING ZONE
CRUSHING ZONE

TELESCOPIC ARM

Operating the Telescopic control lever extends and retracts the inner slew arm through 800mm.



TRAPPING ZONE
CRUSHING ZONE

As the control is mounted to the inner slew arm, it will move as the telescopic control. The operator must work in the control area of the post driver to avoid all trapping zones.

REAR LEG

Operating the Rear Leg control lever extends and retracts the leg and foot plate which is powered down once the mast is in position to stabilise the machine during the post driving operation.

Feet must be kept clear from this crushing zone during operation of this control.



TRAPPING ZONE
CRUSHING ZONE

Operating the Mast Forward Tilt control lever pitches the mast forward and back (23 degrees forward and back from mast vertical position). This maintains a vertical mast while on undulating ground.



Check clearance prior tilting your mast

Operating the Mast Side Tilt control lever pitches the mast side to side (35 degrees each side from mast vertical position). This maintains a vertical mast while on undulating ground.



Check clearance prior tilting your mast.
Keep people away from this trapping zone during this operation.

DRIVER WEIGHT CONTROL

Operating the Driver Weight control will immediately raise and lower the weight. Everyone must be kept clear from this crushing zone during operation of this control.



CRUSHING ZONE
TRAPPING ZONE

TRACK EXTENSION

Operating this control extends the left side track to give the machine a wider footprint. Your extension is approximately 500 mm.



Check clearance prior extending your tracks

This controls the telescopic mast



Left Track Control

This controls the left side hydraulic motor. Moving the lever forward will move the track in the forward direction, and moving the lever backwards will move the track in the reverse direction

Right Track Control

This controls the right side hydraulic motor. Moving the lever forward will move the track in the forward direction, and moving the lever backwards will move the track in the reverse direction



TRAPPING POINT
CRUSHING ZONE

Before using the rock spike the weight will have to be raised so that the rock spike can be moved into position.

The rock spike is located on a support pin when not in use. Raise the rock spike using the control lever to give clearance, then manually swing into position.



The rock spike control valve is used to maintain sufficient clearance of the support collar from the head of the rock spike.



Connect the Auger head / hydraulic pipes

 Beware to connect your pressure and drain pipe to the right couplings.

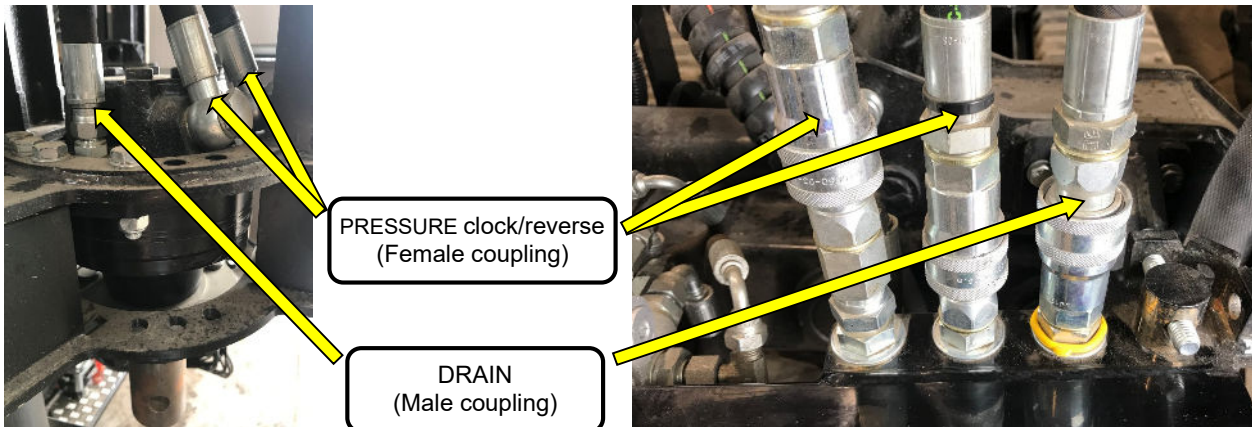

1. Put machine in 'park' position.



2. Lower rear leg for stability.

3. Raise the weight.

4. Use 'rock spike' lever to swing the auger into position.

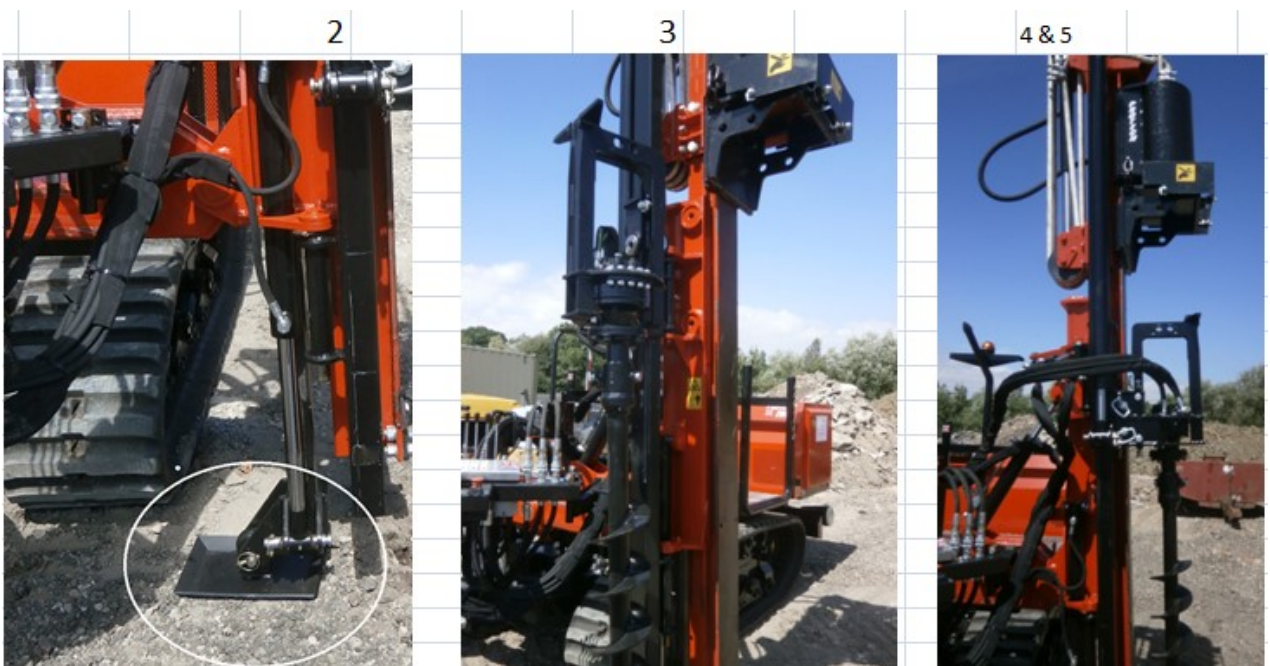

5. Slowly lower the weight to lock the auger in position



- 6. Use the `Right Track` lever to rotate the drill and `Rock Spike` lever to lower the drill
- 7. On completion, `right track` forward and `rock spike` up.
- 8. Lift the weight up clear of the auger.



- 9. Use the `rock spike` lever to swing the auger clear of the mast



10. AUGER CONTROLS

The recessed screw controls the hydraulic power to the auger motor.
The speed control is `clockwise` to slow down and `counter clockwise` to speed up

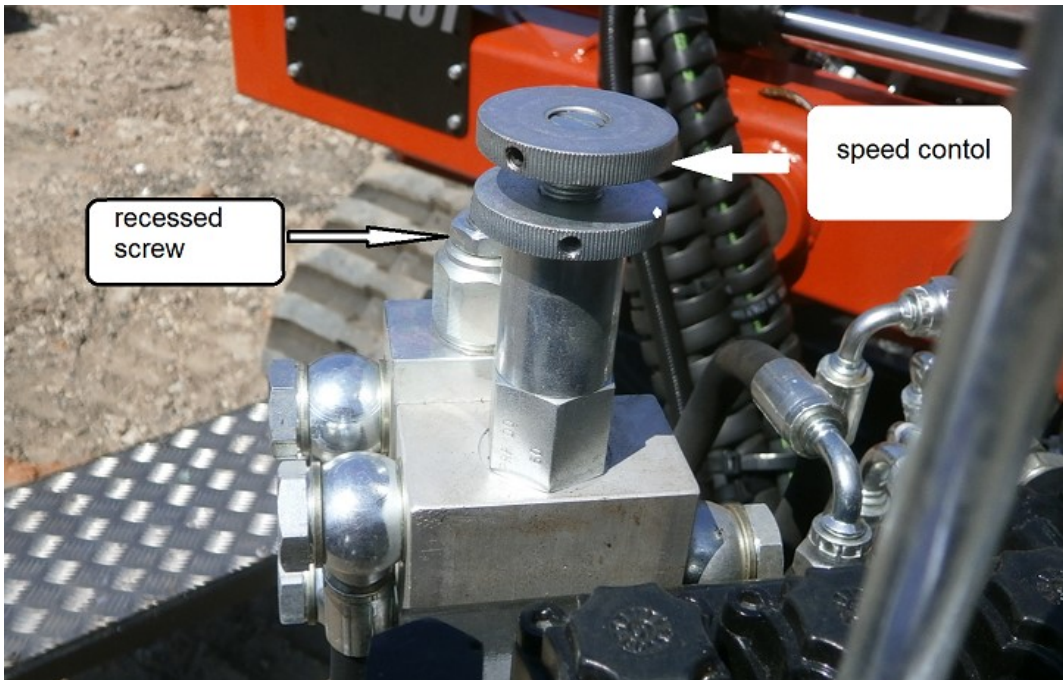

Auto-level operating

Your machine has been fitted with Protech auto-level system. This is a single button hit to level your mast.



2-Axis Auto Levelling system

One-push button to align your post-driver mast to the vertical position.

One of contractors' favourites, as it is a Substantial time saver for intensive fencing.



Just beware your mast has enough clearance before hitting the button as it will start moving immediately

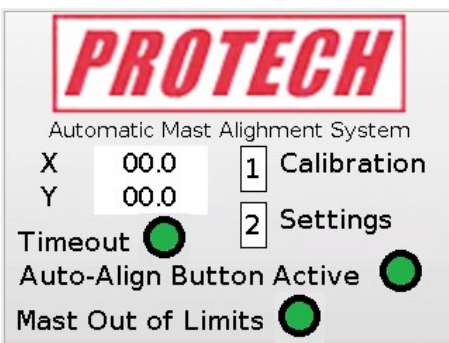

'Timeout' turns green when the auto-align button is held for more than a certain amount of time (time can be adjusted in the settings window).

'Auto-Align Button Active' turns green whenever the button is pressed.

'Mast Out of Limits' turns green when the mast is greater than or equal to $\pm 30^\circ$.

Auto-level setup

You should not have to go to setup as the fixture has been calibrated at factory. After intensive usage or due to power shortage, you may have to re-calibrate. In such case, follow the instructions below :

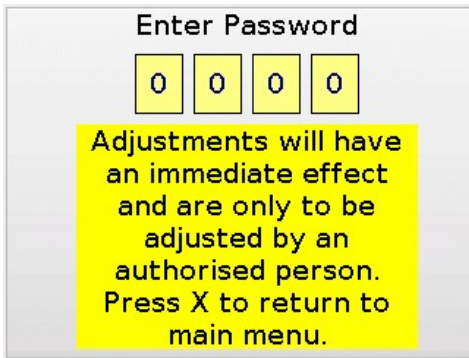

By pressing the arrows then enter buttons, the calibration and settings windows can be accessed.

Use the arrows to highlight a digit, press enter to select the digit, use the arrows again to increase or decrease the digit and press enter again to deselect the digit. Repeat for the remaining digits. Once the password is entered, it will automatically take you to the settings window.

The password is set as 4925.

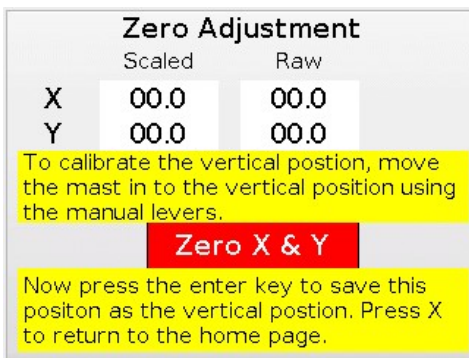

Before using a spirit level, the user can get the mast in an approximate even position by using the hydraulic levers. The raw value from the inclinometer may read different to the scaled values but it's the scaled values that the PLC uses to adjust its alignment. Once the user is satisfied with their angles, they can press the enter button and the scaled values will set to 0.

Pressing the X button on any window will return to the home screen

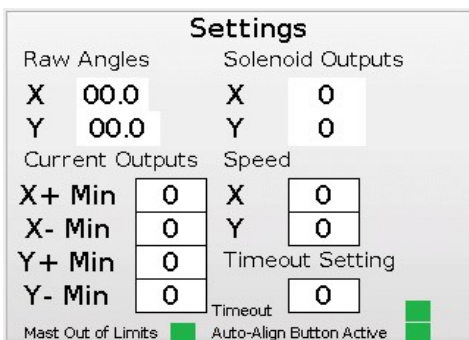

The raw values can display up to $\pm 90^\circ$ on both axes.

The solenoid outputs are scaled -100 – +100.

Minimum current outputs can be adjusted by the user. Use the arrows to highlight a digit, press enter to select the digit, use the arrows again to increase or decrease the digit and press enter again to deselect the digit. The current will change as the value is edited.

The speed of which the cylinders move can be changed here, again by using the arrow and enter keys. The speed is scaled 0 – 100 on both axis. There may be no movement at low values.

The maximum time in which the PLC outputs when the auto-align button is pressed can be changed here. The time setting ranges from 1 – 60 seconds.

Overview.

Your machine has been fitted with remote control system. Please read carefully and understand the operation. Failure to read and fully understand this information could result in injury or death.

The Evo 1 you have purchased has the following options:

- Forward and reverse tracking.
- Weight raise and drop.
- Extending track for counter balance and stability.
- Throttle up and down.
- Park brake operation.
- High speed tracking operation.



The above image is of your transmitter with the controls numbered, Please observe the the following page for the functions and operation. Please read carefully and understand.

1. Left track control for forward and reverse operation.
2. Right track control for forward and reverse operation.
3. Extending track control.
4. Raise and lower the weight control.
5. Rpm control (keep in manual setting, this machine has no auto rpm).
6. Park Brake control switch.
7. Engine speed rpm control.
8. High speed selector switch.
9. 20% track control adjustment switch.
10. Emergency stop switch (will only stop Scanreco system).
11. Remote on button.



Before operation of the radio control system.

Please be advised that when the radio control transmitter is switched on and paired to the receiver it will override the park brake and high speed tracking switch functions. The throttle and tracking will operate on both independently.

Before starting the engine, check that the park brake is on and in low speed tracking. This can be done by observing the warning light indicators. The park brake should be illuminated and the hare symbol not.

Now check that the switches on the transmitter are also in the park brake on and low speed selected position. This is done by checking that switch's 6 and 8 are toggled to the left.

Manual operation without transmitter.

To begin you will have to release the park brake, operate the switch to the right of the control levers. When the brake is released the park warning lamp indicator will extinguish. Carefully pushing the track control levers will allow the machine to move forward or backwards. To change up to high speed tracking, operate the switch located on the control housing next to the warning lamps. The hare warning lamp indicator will illuminate showing the speed has changed.

Operating the lower switch will control the engine rpm, pushing it to the left will increase the rpm and to the right will decrease the rpm. Set rpm to the desired speed.

Approximately 2000 rpm is recommended.

Remote control operation.

When using the remote you should always set the manual switch controls to Park brake on position and low speed selected. This is advised because when the transmitter is switched off or loses signal with the receiver the system reverts back to manual control and the brake will be applied. When the transmitter is on it overrides all manual control, so setting this to a safe position means the machine is under control by the user at all times.

To switch on remote, pull out emergency stop switch on the receiver and hold the on button for a few seconds. When the remote is on it has full control of the park brake and high speed tracking. Release the park brake by toggling switch 2 to the right. The park brake warning lamp indicator will extinguish. Carefully pushing the levers 1 & 2 forwards or backwards will cause the machine to track respectively. To change to high speed tracking toggle switch 5 to the right and the hare warning lamp indicator will illuminate indicating that the speed has been selected.

Operating the rpm+ or rpm- will control the engine speed accordingly.

As a test of operation, the user can push the emergency stop button on the transmitter and observe the warning lamp indicators. If set up correctly the park brake should illuminate and the hare lamp should extinguish as control has been returned to manual operation.

Your machine has been fitted with welder capability for steel posts operations. The welder power pack is built into the, with connections and on/off switch located on the side of the machine. The welding output is totally isolated from the machine electrical circuit.

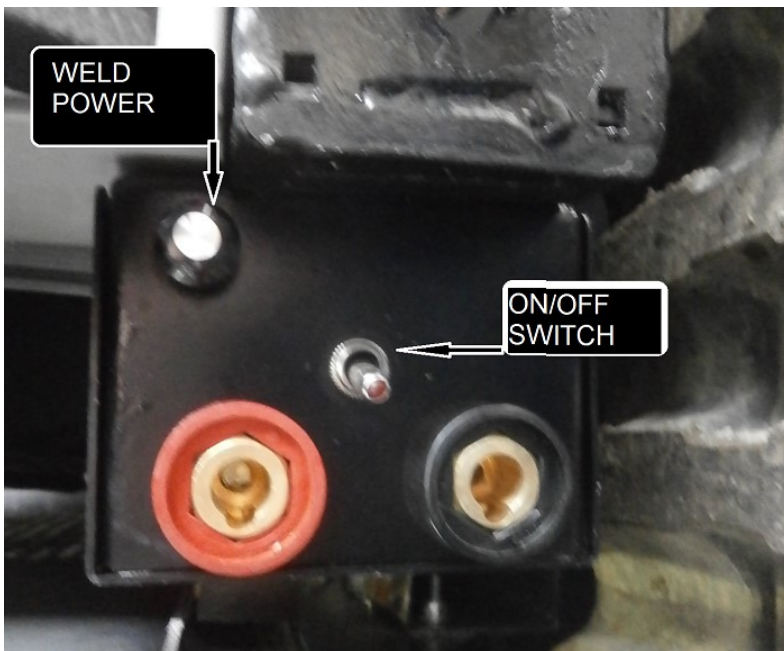

To operate the welder, manually move the lever at the rear of the machine to control the hydraulic motor which drives the welder power pack. Turn the toggle switch to the `ON` position, this will be confirmed by the internal led on the toggle being illuminated. Connect welding leads, and adjust the rotary control for desired power.



INITIAL CHECKS BEFORE OPERATION

Before operation, please check and inspect the following:

- Engine oil level
- Coolant level
- Fuel level
- Hydraulic oil level
- Park brake operation
- Safety devices are working correctly
- Transportation devices have been removed and locking pins reinserted
- All warning labels are clear and visible
- No major leaks from any of the systems
- There is no major damage to the machine
- The person operating the machine has been trained and competent

OPERATING THE DRIVE MOTORS AND MOVING THE MACHINE



Failure to observe the following could result in *Serious Injury* or *Death*

After the initial checks have been carried out we can start with moving the machine. If moving the machine over long distances it is advised that the transportation bars be fitted and the mast lowered into the stowed position.

Please ensure that no person is in front or around the machine before operating. Only one person is also allowed to ride the machine and that is the person controlling it. Please do not allow persons to ride the machine under any circumstances.

Firstly start the engine ensuring the park brake is applied, this is indicated by the red park brake lamp. Allow engine to warm slightly before moving. When ready and taking both track drive levers, release the park brake and gently push them forward together. This will then supply hydraulic pressure to the track motors and move the machine forward.

Carry out the same process but instead pulling the levers backwards causes the machine to track backwards. To turn direction, gently push one of the levers further forward or backwards than the other. This will cause one of the tracks to rotate quicker giving the turning effect required. The further forward or backward the lever is in relation to the other determines how quick the machine will turn.

To rotate the machine with no forward or reverse travel, gently push one lever forward and the other equally backwards at the same rate. This will cause both tracks to rotate in opposite directions allowing the machine to rotate on the spot.

Once accustomed to the operation of tracks you can increase the engine rpm providing more hydraulic fluid to the track motors.

To use the machine in the higher geared mode `fast`. Stop the machine and apply the park brake. Toggle the hare switch to on this will be indicated by a green lamp. When ready release the park brake and carefully push the track control levers in the required direction of travel. Please be careful in this mode, although control levers are progressive, the machine can move quite quickly from the start. Ensure to be stood in a stable position when operating track movement.

USING THE POST DRIVING EQUIPMENT



Failure to observe the following could result in *Serious Injury* or *Death*

When the machine is in position, apply the park and remove any transportation bars that may be fitted ready for operation. After checking your surroundings for any hazards and observing the relevant labeled lever, move it in the required direction of travel. This will supply hydraulic pressure to the associated ram causing it to either extend or retract. Please be aware that moving hydraulic mechanisms can cause severe crushing injuries or **Death**.

Once you have the mast in the required position, lower the leg to the ground supporting the rear of the machine. Please be aware that this is a crush zone and caution should be taken to prevent injury.

Carefully raise the hammer and gripper plate together to the required height of the post. Standing aside, insert the post under the gripper plate locating it in the three small spikes.

When ready, lower the hammer and gripper plate down on to the post and remove the links attaching the gripper plate to the hammer.

NEVER place any body part or object between the gripper plate and hammer.

Raise the hammer slowly and smoothly to the top avoiding the end stop and allow to drop on to the gripper plate. At this point the force will be transferred in to the top of the post via the gripper plate and thus driving the post into the ground. Repeat this operation until the post has been inserted to the required height. Once complete, lower the hammer on to the gripper plate and reattached the links. Raise the gripper plate from the post and rear leg. You can then move onto the next position.

To use the rock spike, carry out the same operation but with the rock spike under the gripper plate. You may have to constantly adjust the rock spike retraction system to allow for ease of movement. After you have made the required pilot hole, raise the hammer and gripper plate together. To remove the rock spike from the ground operate the required lever to pull the rock spike from the ground using the rock spike retraction system.

A falling hammer weight can be fatal and every caution should be taken to prevent injury or **Death**

Switches and Controls

From left to right the switches are:- lights, fast, throttle control, engine control, e-stop and park.



Lights. This switch turns on/off the work lights as required, and is internally illuminated when operated.

Fast. This will operate the fast solenoid and switch the hydraulic motors to fast speed. The switch is internally illuminated when fast speed is selected.

Throttle. This is a momentary action switch for engine throttle control. The throttle is controlled by an electrically operated transducer. Pressing the top side of the switch will increase engine revs, and pressing the bottom of the switch will decrease engine revs between min/max limits.

Engine control. This is a 4 position keyswitch:-

- 0 engine off
- I ignition on
- II glow plugs energised
- III engine start

E-Stop. This switch will stop the machine, engine off, and all electric functions turned off. Push the switch button downwards to activate the e-stop. The e-stop is released by pulling the button upwards.

Park. This will operate the park solenoid valve and turn off hydraulic pressure to the brake control of the hydraulic motor. The park function will stop movement of the machine but maintain operation of all other hydraulic control functions. The park function is active when right hand side of the switch is depressed, switch will be internally illuminated.

Junction box.

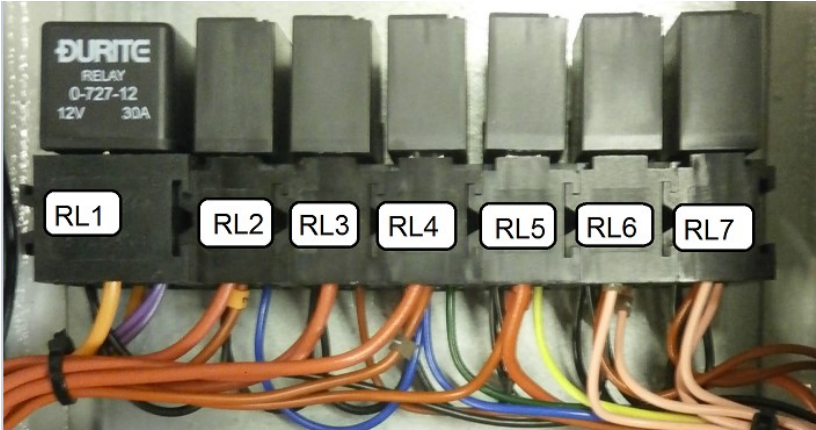

RL1	Emergency stop
RL2	Diverter
RL3	Lights
RL4	Park brake
RL5	Fast speed
RL6	Throttle +
RL7	Throttle -
FUSES	As indicated in the box

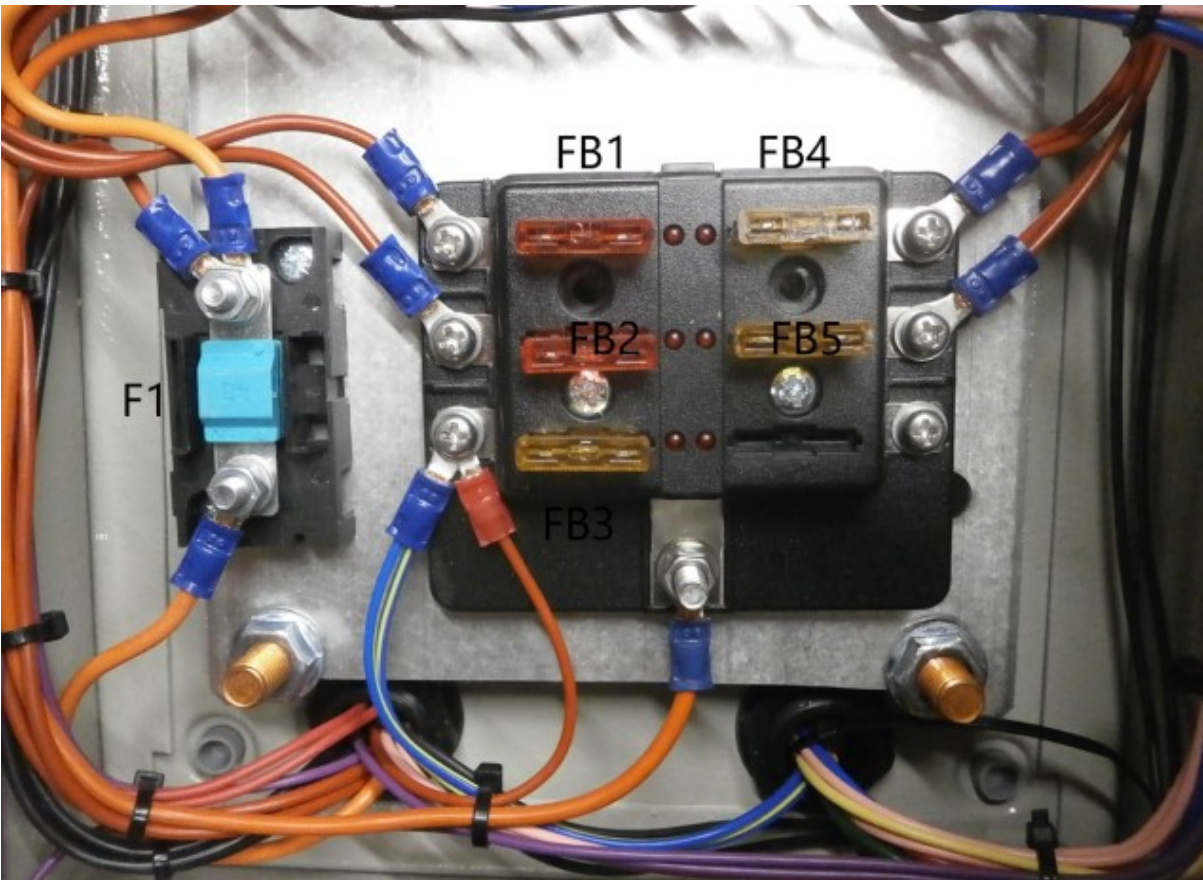

Circuit Diagrams.

Machine diagram

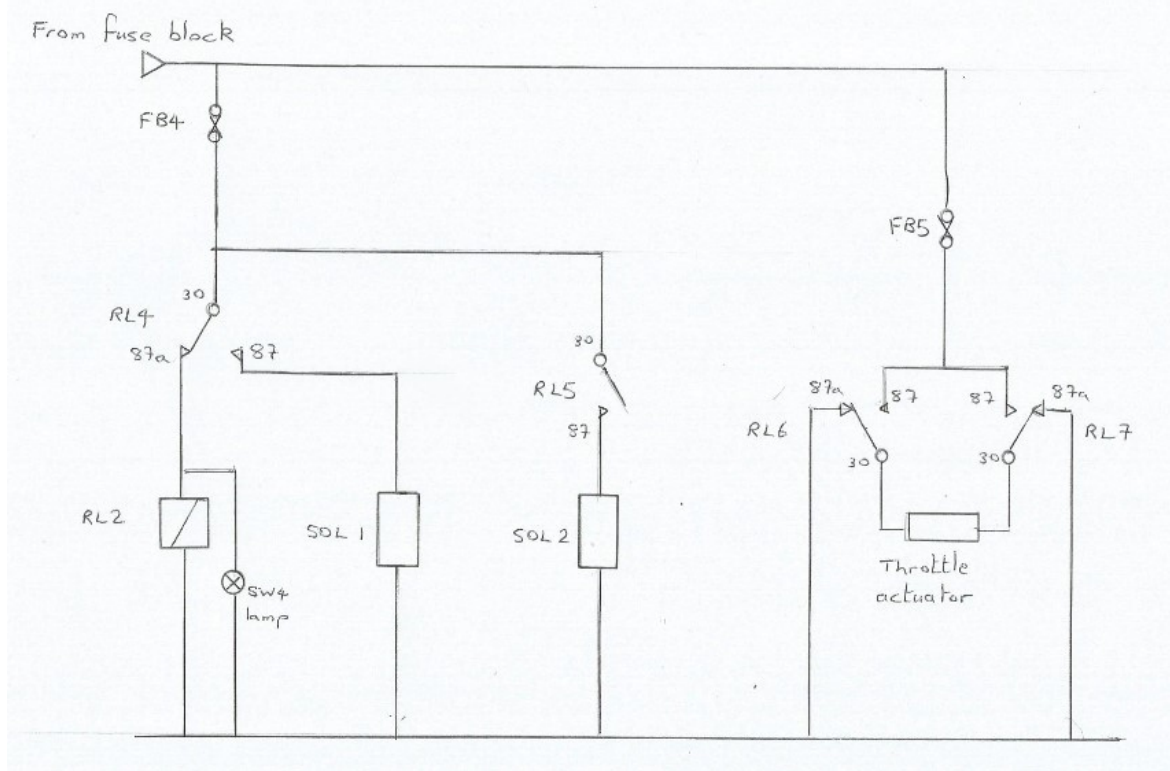
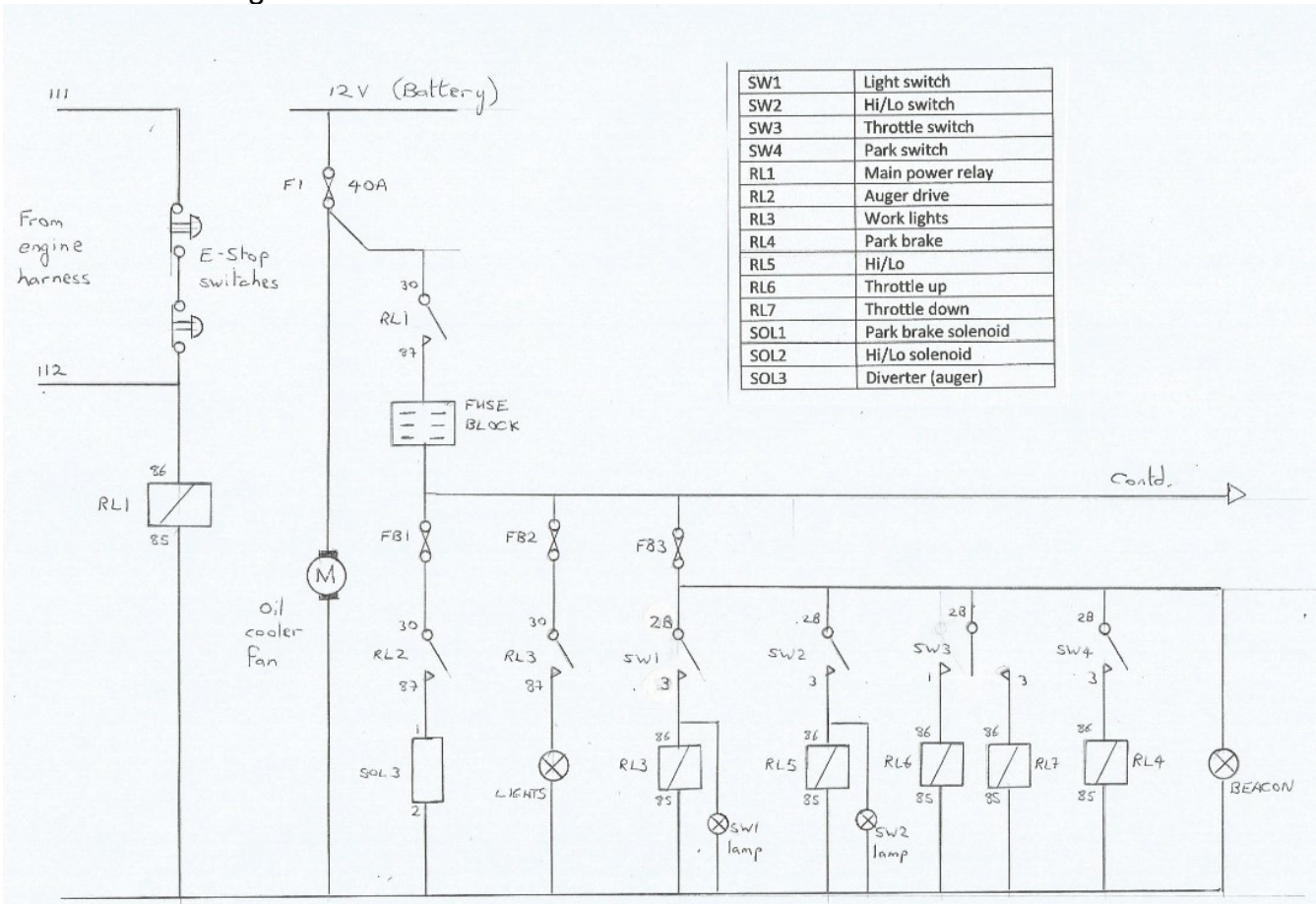

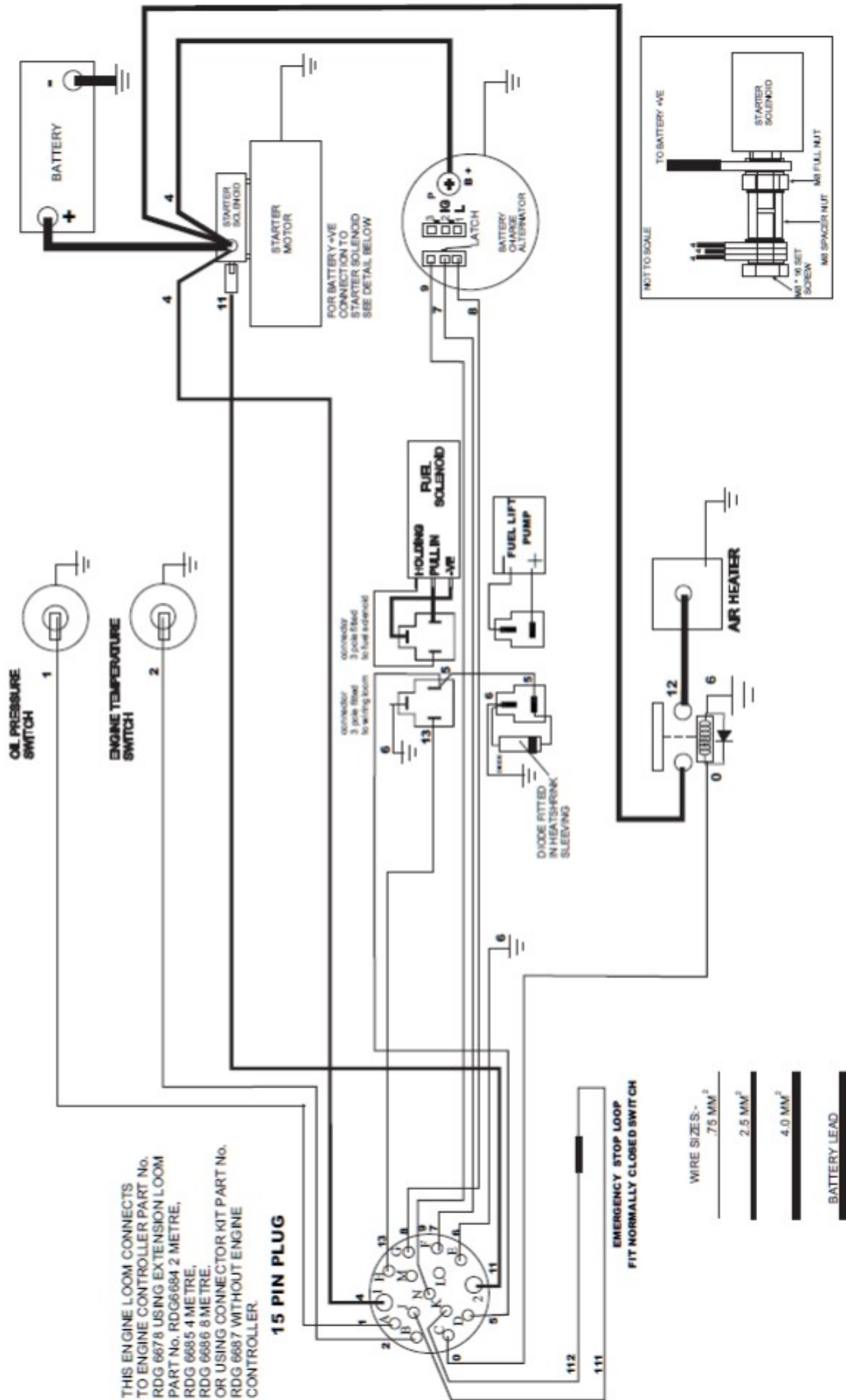

Engine diagram



Engine control box.

Normal operation

“0” : standby

“I” :  LED on top
  energise battery





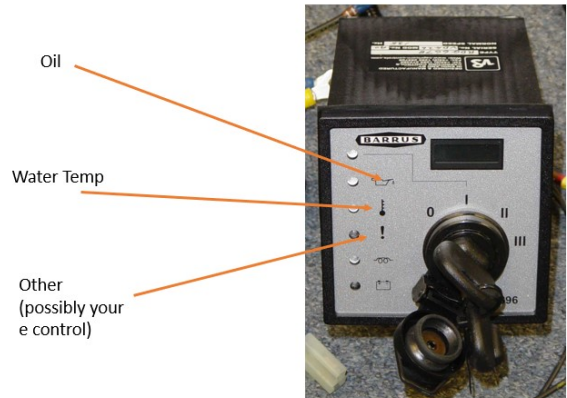



“II” : pre-heating
  is on

“III” : engine kick-starts, release to position “I”







Engine monitoring / issues

In the event of an engine shutdown, the fuel solenoid de-energises and the engine stops. The appropriate LED displays.

-   Battery charge fail (battery or alternator) / flashes if fan belt fails
-   Low oil pressure (pressure sensor)
-   High engine temperature (temp sensor) / Cooling fault (radiator defect) / Engine shut down without standard fault (running out of fuel or other)
-   Emergency button was hit / e-circuit is open

If position “I” > 25 seconds

Without cranking and running the engine, the control module with shutdown

-   ON
-   WILL EXTINGUISH,

If the key switch is held in position at start up, the starter will automatically disengage at 600 RPM. If engine does not reach 600 RPM despite staying on position “III” for 25 s, the engine will shutdown and  ! will display. Return key to “0”.

If the engine has run >25 s, and key switch is turned to “III”, engine will shutdown and  ! will display. Return key to “0”.

Daily

Check the lift rope for any signs of wear. If in doubt, change the rope.
Check hydraulic hoses for any signs of wear. If in doubt change the hose.
Grease the mast where the driver weight runs.
Check all nuts and bolts are tight.

Weekly

Check the hydraulics for leaks
Check the rope pulleys turn freely
Check all pivots for wear
Grease all pivots



Grease all pivots



Take special care to rollers which require bearings to be greased with multipurpose grease stuffed with a grease pump to create an internal pressure and avoid water and moisture ingress.



Use a manual or pneumatic grease pump gun for track tension and general greasing

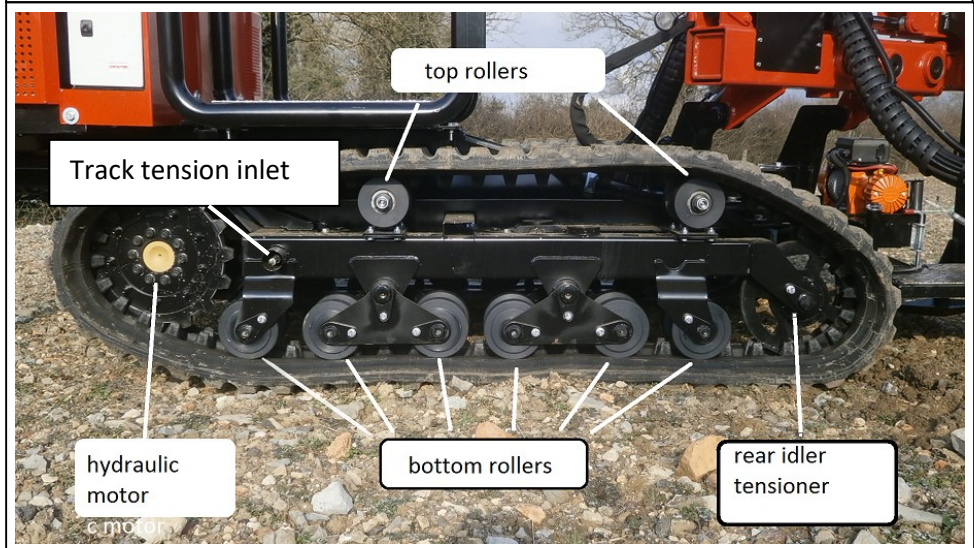

Machine operated in water and sea side :

Grease generously with a grease pump using general purpose grease. Bottom rollers (outside only) and Top rollers (inside and outside) and rear idler wheel require weekly greasing when machine is operated in severe conditions.

Machine operated in dry / mixed weather conditions :

Thorough monthly greasing is enough.

Monthly maintenance

Check engine oil level, top up as necessary.
Check hydraulic oil level, top up as necessary.
Check engine coolant level, top up as necessary.
Check tightness of wear pads. Tighten as necessary.



Coolant level needs checking monthly



Oil level needs checking on a monthly basis. If temperature exceeds 70 degC on a regular basis, check cooler fan is operating normally



BEWARE: On EVO2 and EVO3, your machine will be fitted with a 350 bar hydro-pneumatic accumulator to supplement track tension. If needed, nitrogen pressure must be controlled with appropriate equipment and by a trained person. Please contact your hydraulics local dealer.

Yearly maintenance

Drain and replace hydraulic oil
Replace hydraulic oil filter
Drain and replace engine oil
Replace engine oil filter
Replace fuel filter

TRACK TENSION

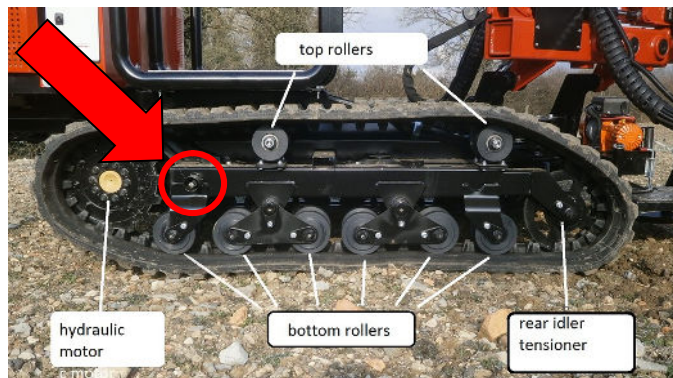

Use a grease gun to feed grease into the cylinder to obtain 20-30 mm slack when pushed with a weight of 60 Kg

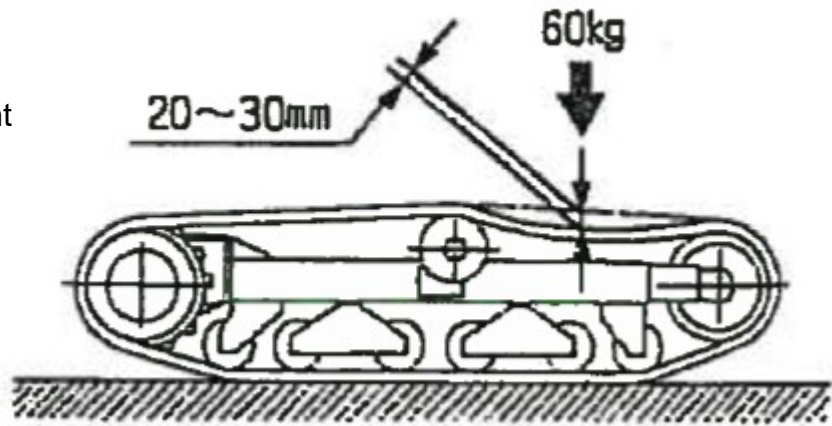

HYDRAULICS SERVICING

Mechanical parts / greasing points: we recommend **multipurpose grease - generously**



Hydraulic system oil: we recommend using :

- **HV46 - High viscosity oil**
- 10µm oil filter PROTECH ref. HVSZ0008
- Change filter every 500 hours or 1 year maximum

On a warm engine, if your indicator goes in **yellow**, change filter rapidly. If **red**, stop using the machine until new filter in place.

ENGINE SERVICING

Always refer to your specific Yanmar engine documentation for servicing.

First servicing after 50 hours as recommended by Yanmar and every 500 Hours or 1-year maximum intervals after first servicing.

Engine coolant: refer to YANMAR documentation. We use standard blue coolant

Engine oil: refer to YANMAR documentation. We use **10W30** engine oil – ACEA E3 minimum (E4, E5 and more are best – see engine documentation for more details)

- EVO COMPACT (YANMAR 3TNV76) : engine oil quantity **3.5 Litres approx.**
- EVO1S (YANMAR 4TNV88DS or 4TNV88C) engine oil quantity **5 Litres approx.**

Engine fuel: diesel



TROUBLE SHOOTING

Symptom	Possible cause	Solution
Engine cut out	Fuel supply. Refer to engine control box	Check filters, air inlet, suction hose in tank Contact dealer
Engine cut out	Electrical cause, emergency line, cut-out solenoid. Refer to engine control box	Check emergency line Change cut-out solenoid Contact dealer
Track damage	Excessive tread wear. Loosening/breaking of internal structure.	Replace track
Track slackens frequently	Faulty tensioner valve. Worn tensioner components	Replace valve Replace worn components
Upper track does not stay in position	Upper track rollers worn	Replace track rollers
Lower track does not stay in position	Lower track rollers worn	Replace track rollers
Track `jams` when steering the machine	Material (stones, rocks, earth etc.) trapped between rollers, drive sprocket and tensioner.	Remove material by turning the track in both directions. Raise the machine at the same time if possible
Oil leakage	Hardened seals Seals damaged or worn	Clean around component and recheck after a few days Contact dealer
Excessive noise	Internal malfunction Worn seals	Contact dealer
Overheating	Lack of oil Brakes binding	Add oil Check brake release pressure
Motor runs but drive sprocket not turning	Internal malfunction Brake jammed	Contact dealer Check brake release pressure
Brake not releasing	Lack of brake pressure Faulty break seals	Check brake connections Contact dealer
Brakes not locking	Residual pressure in circuit Worn break components	Check hydraulic system Contact dealer



CHECKLIST

Who can carry out the plant / equipment documented inspection?					
<p>All plant / equipment must be inspected and signed off by a competent person. A competent person is:</p> <ul style="list-style-type: none"> A person that has been trained to use the plant / equipment being inspected or A person who has a good understanding and knowledge of the plant / equipment being inspected. 					
What is required?					
<ul style="list-style-type: none"> All plant / equipment must have a documented inspection prior to its use. A documented inspection only has to be carried out once a week however plant / equipment MUST always be inspected prior to its use. Under no circumstances is plant / equipment to be used if a defect has been identified. Under no circumstances is plant or equipment to be used if it is not within the service date displayed on its service tag. Contact your Manager if you have any queries. 					
How to use the plant / equipment inspection sheet					
<ul style="list-style-type: none"> Tick Yes or No to confirm that the question in the appropriate section has been answered. If the question is not applicable to the equipment being inspected tick N/A. Finally sign, print your name and date to confirm the plant has been inspected. 					
IMPORTANT – Plant and equipment must only be used for a task that it has been designed for.					
Plant / equipment details					
Plant identification number	Description	Service date			
Generic Questions for EVO Machine			Yes	No	N/A
Are all warning and information signs fitted, legible and understood?					
Are all controls working correctly:-					
Beacon operational					
Emergency stop					
Park switch / hydraulic brake					
Engine start / stop					
Throttle control, up / down					
Mast Slew control					
Mast side tilt control					
Mast forward tilt control					
Mast telescopic control					
Foot plate control					
Driver weight control					
Rock spike control					
Are all dangerous parts of the plant / equipment adequately guarded?					
Are there any visible signs of damage, leaking to hydraulic hoses or hydraulic controls?					
Are cables in good order and free from any damage					
Are the tracks and rollers free from damage					
Are the correct tools available for adjusting the plant / equipment?					
Inspection carried out by:	Signature	Print	Date		



PROTECH MACHINERY LTD

Woolridge Farm, Gloucester Road, Hartpury, Gloucester GL19 3BG

Tel: 01452 700 713 Email: sales@protechmachinery.com

Company reg. no. 4958012

VAT no. 834 1361 48