



DW20

Wheel Dumper

The little one with a bit more in terms of safety

The hydrostatic 4-wheel drive of the DW20 guarantees good traction and machine control throughout the whole operation. The ideally shaped handles in direct reach of the operator provide the right support in any situation. The machine is equipped with tilt and skip monitoring ex works, which take safety to a new level with the hill-hold function and seatbelt monitoring. The optional start release for the seatbelt monitoring thinks and allows the machine to only then start operation if the seatbelt is applied after the operator sits down.

Highlights

- Inclination monitoring
- Skip monitoring
- Hydrostatic 4-wheel drive
- Hill-Hold function
- Small dimensions

Technical Data

Hydraulic

Operating pressure	210.0 bar
hydraulikpump	ZRP
Flow rate	23.0 l/min
Hydraulic system content	31.0 l

Mechanical - Output Details

Travel speed	20.0 km/h
--------------	-----------

Mechanical Details

Length	3,706.0 mm
Width	1,497.0 mm
Height	2,738.0 mm
Payload	2,000.0 kg
skip	Swivel skip
Skip capacity levelled	950.0 l
Skip capacity heaped	1,280.0 l
Skip capacity waterlevel	700.0 l
Pendulum angle	15.0 °
Operating weight (min.-max.)	1,955.0 - 2,545.0 kg

Engine

Cooling	Water-cooling
Motor type	Diesel engine

Cylinder	3.0
Cylinder capacity	1,116.0 cm3
Inclined position max.	25.0 °
Tank capacity	35.0 l
Effective power	18.9 KW
Nominal Engine speed	3,000.0 1/min
Exhaust-gas limit	EU Stage V
Starter battery Voltage	12.0 V
Manufacturer	Yanmar
Engine designation	3TNV76-UDWN

Environment Data

Sound power LWA, measured	98.1 dB(A)
Sound power LWA, guaranteed	101.0 dB(A)
Sound power LWA (Standard)	ISO 6395

Operating Fluids

Fuel specification	Diesel EN 590
Fuel Tank capacity	35.0 l

Chassis

Turning radius	3,800.0 mm
Articulation angle	36.0 °
drive unit	Swash plate motor

hydraulikpump	Axialpistonpump
Operating pressure	470.0 bar
Flow rate	66.0 l/min

tires	10.0/75 - 15,3 AS ET-40
-------	-------------------------

■ **Shipping and Storage**

Shipping weight	2,034.0 kg
-----------------	------------

Dimensions

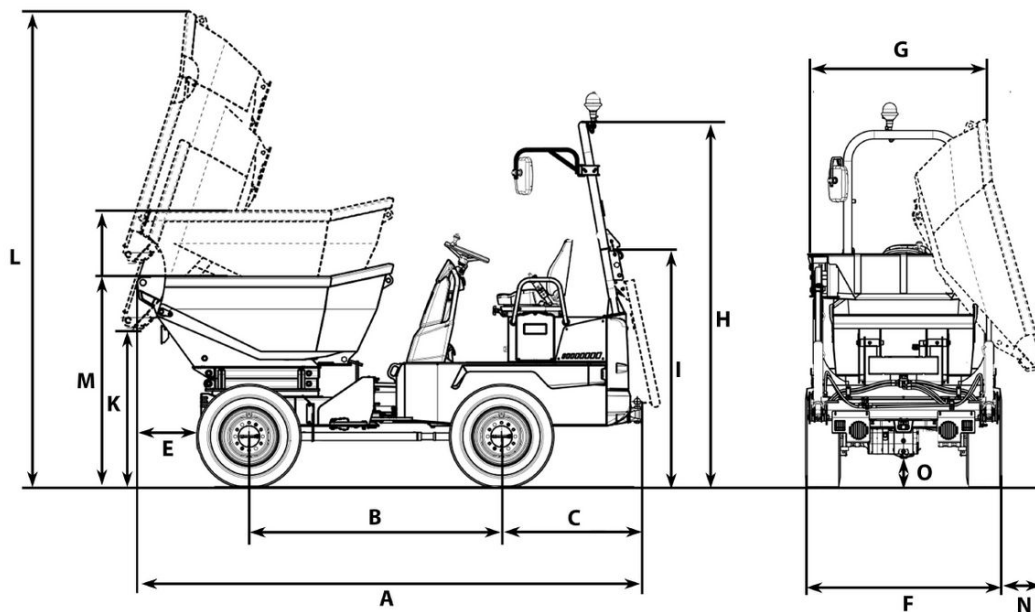

A	Total length	3,784 mm
B	Wheel base	1,882 mm
C	Rear overhang	1,041 mm
E	Dumping width	481 mm
F	Width of vehicle	1,497 mm
G	Width of skip	1,482 mm
H	Height ROPS	2,738 mm
I	Height of ROPS tilted	1,873 mm
K	Height	910 mm
L	Skip height tilted	2,855 mm
M	Skip height	1,404 mm
N	Dumping width lateral	241 mm