



DV45

Dual View Wheel Dumper

The next level of the Dual View dumper

The cabin can be rotated when driving at the press of a button on the right joystick. The optional Multi View mode therefore provides the ability to work with a cabin turned to the side in order to have an overview to the side of the machine and the skip. At the press of a button, the cabin is automatically rotated, whereby the operator can concentrate on the primary work. Additional safety features round off the optimal overall package with a maximum payload of {4,200kg} {9,259lb}. The DV45 is simultaneously characterized with the familiar high level of comfort features, the very good stability, and the hydrostatic 4-wheel drive with ECO mode.

Highlights

- Rotating cab
- Multi View Mode
- Automatic skip return
- Inclination monitoring
- Entry and exit possible on both sides

Technical Data

Hydraulic

Operating pressure	240.0 bar
Tank capacity	53.0 l

Mechanical - Output Details

Travel speed	25.0 km/h
--------------	-----------

Mechanical Details

Length	4,400.0 mm
Width	1,780.0 mm
Height	3,274.0 mm
Weight	4,114.00 kg
Weight cabin	4,640.0 kg
Payload	4,200.0 kg
skip	Swivel skip
Skip capacity levelled	1,810.0 l
Skip capacity heaped	2,400.0 l
Skip capacity waterlevel	1,350.0 l
Pendulum angle	15.0 °

Engine

Cooling	Water-cooling
Motor type	Diesel engine

Cylinder	3.0
Cylinder capacity	1,663.0 cm3
Inclined position max.	20.0 °
Fuel type	Diesel EN 590
Tank capacity	53.0 l
Effective power	36.0 KW
Nominal Engine speed	2,300.0 1/min
Exhaust-gas limit	EU Stage V
Starter battery Voltage	12.0 V
Manufacturer	Perkins
Engine designation	403J-E17T

Environment Data

Sound power LWA, measured	96.7 dB(A)
Sound power LWA, guaranteed	101.0 dB(A)
Sound power LWA (Standard)	ISO 6395

Operating Fluids

Fuel specification	Diesel EN 590
Fuel Tank capacity	55.0 l
Fuel Tank Volume	46.0 l

■ Chassis

Turning radius	4,465.0 mm
----------------	------------

Articulation angle	36.0 °
--------------------	--------

drive unit	Swash plate motor
------------	-------------------

hydraulikpump	Gear pump
---------------	-----------

Operating pressure	240.0 bar
--------------------	-----------

tires	11.5/80-15,3 - 14PR
-------	---------------------

■ Shipping and Storage

Shipping weight	2,991.0 kg
-----------------	------------

Dimensions

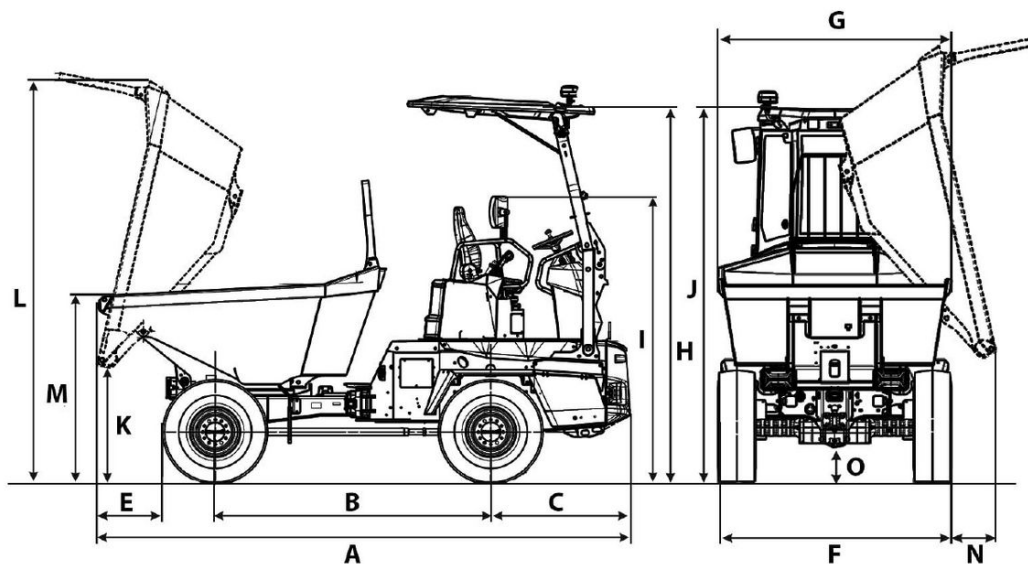

A	Total length	4,400 mm
B	Wheel base	2,280 mm
C	Rear overhang	1,155 mm
E	Dumping width	503 mm
F	Width of vehicle	1,780 mm
G	Width of skip	1,775 mm
H	Height ROPS	3,060 mm
I	Height of ROPS tilted	2,363 mm
J	Height with cab	2,841 mm
K	Dumping height max.	945 mm
L	Skip height tilted	3,317 mm
M	Skip height	1,634 mm
N	Dumping width lateral	335 mm