

**P11104DC** (For flat materials)  
**P11004DC** (For curved materials)  
**P1HV1104DC** (For rough materials)

In addition to a modular design, these Powr-Grip® vacuum lifters provide 180° rotation and 90° tilt, for expandability and a full range of load motion at the installation site or on the shop floor.

Channel Lifters are comprised of one or more Pad Channels and interchangeable Lift Frames for manually rotating and tilting materials. They may be ordered as complete units or as individual components to expand existing Channel Lifter systems. Lift Frames are available in single-channel or double-channel styles. Pad Channels can be switched from one frame to another in minutes.

**Standard Pad Spread:** P11104DC: 51 x 12" [1295 x 305 mm]  
P11004DC: 49" x 10" [1245 x 254 mm]  
P1HV1104DC: 50" x 11" [1270 x 280 mm]

**Number / Size of Pads:** P11104DC: 4 / 11" [28 cm] dia. lipped  
P11004DC: 4 / 10" [25 cm] dia. concave  
P1HV1104DC: 4 / 10" [25 cm] dia. lipped

**Load Capacity:** P11104DC: 700 lbs [320 kg]  
P11004DC: 600 lbs [270 kg]

(Capacity is reduced on curved surfaces.  
Please contact us for capacity on curved surfaces.)

**P1HV1104DC: 600 lbs [270 kg]**

(On smooth, nonporous surfaces.  
Please contact us for recommendations on other surfaces.)

**Average Unit Weight: 70 lbs [32 kg]**

**Standard Operating Power: 12 volts DC, 10 amps (for each Pad Channel)**

**Load Movement:** Manual rotation, 180° edgewise, with locking in three positions.  
Manual tilt, 90° between upright and flat, with automatic latching in upright position.

(Units can be tilted ONLY when the lift bar is locked in the center position, as shown on drawings.)

- On-board battery and charger
- Battery energy gauge
- Low vacuum warning light
- Vacuum gauge
- Vacuum line filter
- Vacuum reserve tank

### ALTERNATIVE POWER SYSTEMS:

Air (venturi) power system (P11104AIRS, P11004AIRS, or P1HV1104AIRS)

AC power system (P11104AC, P11004AC or P1HV1104AC)

(Specifications may not be as listed above.  
Please contact us for more information.)

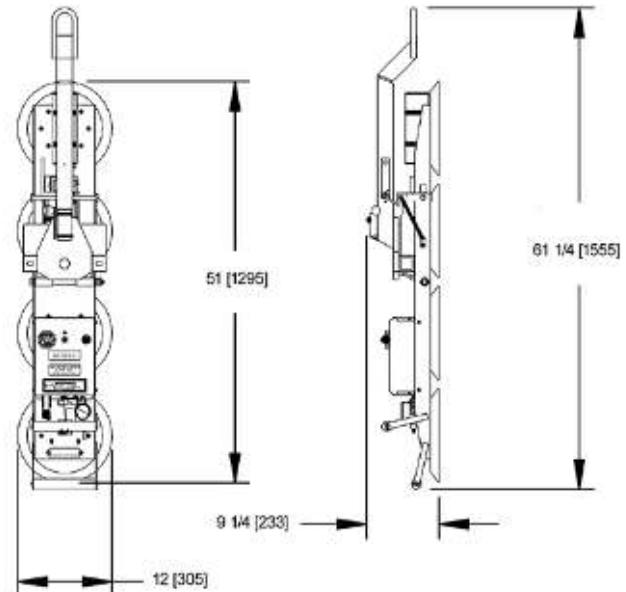

Environmental conditions can affect product performance and longevity; consult the product instructions on [www.powrgrip.com](http://www.powrgrip.com) or contact a Technical Sales Representative for more information. Based on product information at time of publication.



---

## COMPONENTS

### PAD CHANNELS

Each channel features an independent, on-board vacuum generating system, including vacuum pump, vacuum controls and standard features as listed above.

**PC1104:** (for flat materials) 4 / 11" [28 cm] dia. lipped pads

**PC1004:** (for curved materials) 4 / 10" [25 cm] dia. concave pads

**PCHV1104:** (for rough materials) 4 / 10" [25 cm] dia. lipped pads

### LIFT FRAMES

**PCFT1A1:** For one Pad Channel

**PCFT2SA45:** For two Pad Channels, approx. 4½' [1,38 m] pad spread

**PCFT2SA7:** For two Pad Channels, approx. 7' [2,14 m] pad spread

### INTERCHANGEABLE ARMS

(Pad spread can be changed if optional arms are purchased)

**FA245:** Optional arms convert PCFT2SA7 Lift Frame to PCFT2SA45 Lift Frame

**FA27:** Optional arms convert PCFT2SA45 Lift Frame to PCFT2SA7 Lift Frame

### AVAILABLE OPTIONS:

**Remote control system (EO8RC1)**

**Removable control pendant (EO9RP)**

**Dual vacuum system (EO10DVS)**

**Individual pad shutoffs (CM1COWB)**

**Closed cell foam pad rings (FRHV11)**

(Available on P1HV1104 units only)

**ABS shipping case (53005)**

(see below for more information)

### DESIGN STANDARDS:

(See [www.powrgrip.com](http://www.powrgrip.com) for more information.)

**ASME B30.20 - 2006**

(BTH-1 Design Category "B", Service Class "0")

**CE**

**AS 4991 - 2004**



### ABS Shipping Case for P1 Vacuum Lifters

(vacuum lifter and case sold separately)

- Designed specifically for shipping and storing Powr-Grip® P11104, P11004 and P1HV1104 Vacuum Lifters.
  - Durable thermo-formed ABS construction.
  - Three straps on inside of case hold vacuum lifter firmly in place.
  - Eight plastic buckles attached to nylon straps hold case in closed position.
  - Handles molded into the case structure enable convenient handling.
  - Ribbed exterior of case enables easy stacking of multiple lifters.
  - Case design incorporates grooves on the bottom to facilitate forklift handling.
-